



NOWATA FILTERS PROTECT

COMPRESSORS



FUELING STATIONS



ENGINES



ENVIRONMENT



COMPRESSED NATURAL GAS FOR VEHICLES
CNG Coalescing Filter for NGV

THE FUELGUARD™ STANDS GUARD 24 HOURS A DAY

Nowata's CNG coalescing filter for Natural Gas Vehicles takes out 99.99% of the compressor lube oil that can create real problems for the NGV consumer. With our filter, operators can use a reliable lubricated compressor and have confidence that lube oil carry over has been removed.

The Nowata Filtration FUELGUARD™ filter provides clean dry usable fuel gas for the customer. Nowata's FUELGUARD™ is dependable filtration and clearly does make the difference in having the ability to deliver consistent quality Compressed Natural Gas.

The Nowata FUELGUARD™ filter system is ASME code design and is rated to 6000 PSI pressure. If protecting equipment and the environment are important to you, make sure to have a Nowata Filtration FUELGUARD™ filter on the job.

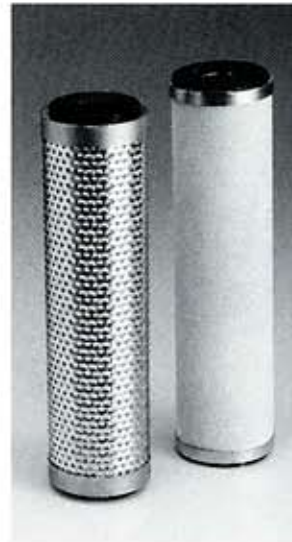
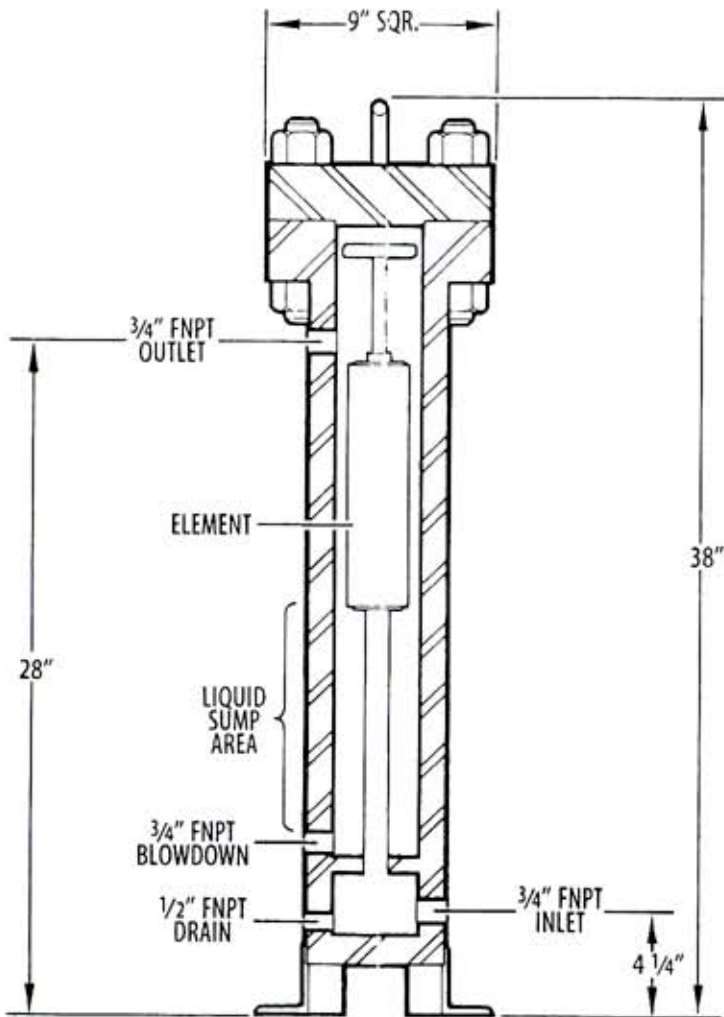

Replaceable Coalescing Element

RECOMMENDED FLOW RATES		
Operating Pressure	Maximum Flow Rate	
	PSIG	SCFM
100	45	2700
200	65	3900
300	75	4500
500	95	5700
750	120	7200
1000	135	8100
1500	165	9900
2000	190	11400
2500	215	12900
3000	235	14100
3500	250	15000
4000	270	16200
4500	285	17100
5000	300	18000
5500	315	18900
6000	330	19800

.65 S.G. Natural Gas at 80F with 3 PSID pressure drop



Division of MAHLE Industrial Filtration

NOWATA FILTRATION

P.O. Box 678 • Nowata, OK 74048 • 1-800-259-2204 • Fax 918-273-2101
Email: mahle.nowata@us.mahle.com • www.nowata.com